



# IIIT BANGALORE

No: MIIT/58/19

Date: 30 January 2019

## Amendment-II

### **Subject: Supply of Office Furniture for Myanmar Institute of Information Technology, Mandalay**

International Institute of Information Technology (IIIT) Bangalore on be-half of Ministry of External Affairs (MEA) invited sealed tenders from eligible bidders for supply of office furniture for Myanmar Institute of Information and Technology (MIIT) at Mandalay in Myanmar on turnkey basis vide NIT No: MIIT/NIT/01/19 dated 7<sup>th</sup> January 2019

2. The following amendments are made in the above-mentioned tender document:

<b>Condition/ Clause Number</b>	<b>Existing conditions as per the tender document</b>	<b>Amended conditions</b>
Section II, Clause 1 Delivery Period/Project Timelines	The delivery and installation at site(s) must be completed within 190 days from the date of placement of supply order by IIIT Bangalore.	The delivery and installation at site(s) must be completed within <b>100 days</b> from the date of placement of supply order by IIIT Bangalore.
Section III, Clause 4, Completeness Responsibility	Notwithstanding the scope of work, engineering, supply and services stated in bid document, any equipment or material, engineering or technical services which might not be even specifically mentioned under the scope of supply of the vendor and which are not expressly excluded there from but which are necessary for the establishment of MIIT in Myanmar in accordance with the specification and executing the contract to establish achievement of performance guarantee parameters, are to be provided for and rendered by the vendor without any extra charge so that the said project is completed in all respect.	Notwithstanding the scope of work, engineering, supply and services stated in bid document, any equipment or material, engineering or technical services which might not be even specifically mentioned under the scope of supply of the vendor and which are not expressly excluded there from but which are necessary for the establishment of MIIT in Myanmar in accordance with the specification and executing the contract to establish achievement of performance guarantee parameters, are to be provided for and rendered by the vendor without any extra charge so that the said project is completed in all respect.  The successful bidder would be provided the installation plan along with purchase order. The installation plan will include the installation scheme as well as the color etc.

Section III, Clause 8: Shipping Documents and Insurance	Final Dispatch Clearance Certificate (FDCC) shall be issued by IIIT Bangalore on receipt of above-mentioned documents from successful bidder. Actual shipment should be done only after receipt of FDCC from IIIT Bangalore.	Final Dispatch Clearance Certificate (FDCC) shall be issued by IIIT Bangalore on receipt of above-mentioned documents from successful bidder and upon satisfactory completion of a pre-dispatch goods inspection by a committee at the successful bidder location. Actual shipment should be done only after receipt of FDCC from IIIT Bangalore.
---	--	---

3. The clarifications/responses to the queries listed in the pre-bid meeting are mentioned Annexure I of this amendment.

4. All other terms and conditions remain same.

**Registrar IIIT-Bangalore**

## Annexure I

### International Institute of Information Technology (MIIT Mentoring Cell)

**Tender Reference:- MIIT/56/18 for Supply of Furniture's for Myanmar Institute of Information and Technology (MIIT) at Mandalay in Myanmar on turnkey basis.**

**Following clarifications/amendments are issued by International Institute of Information Technology, Bangalore:**

SI no	Tender Queries	Clause as published in the tender	Remarks / submission / Justification	Clarifications / Corrigendum / Amendment
01	Section 1, Clause 2.1(b), Page No 4	Earnest Money in the form of Demand Draft/ Bank Guarantee of Rs. 14.28 Lacs from any Nationalized/Scheduled Bank, in favour of 'International Institute of Information Technology, Bangalore' payable at Bangalore as mentioned at Para 6 (Section II).	We request IIIT Bangalore to provide it's Bank details in order to process the EMD since it is mandatory for the bidder's to provide the submit the same to issuing bank for processing EMD/BG/PBG's	Account Name:- International Institute of Information Technology, Bangalore BANK NAME : Canara Bank BRANCH NAME : Electronic City branch BANK ADDRESS: Plot no:- V1-R22, Phase 1 , Tata BP solar road, Electronic city Bangalore 560010 A/C NO. : 3006101006616 IFSC CODE : CNRB0003006 MICR Code : 560015148 BANK CODE : 003006 BRANCH CODE : 003006
02	Section 1, Clause 2.1(b), Page No 4	Earnest Money in the form of Demand Draft/ Bank Guarantee of Rs. 14.28 Lacs from any Nationalized/Scheduled Bank, in favour of 'International Institute of Information Technology, Bangalore' payable at Bangalore as mentioned at Para 6 (Section II).	We have seen in recent tender on behalf of MEA that the FDR is acceptable in such tender's as a EMD submission. We request you to kindly accept the EMD in the form of FDR as making an EMD in the form of Bank Guarantee now days might be time consuming.	No Change.
03	Section 1, Clause 2.1(m), Page No 5	Undertaking to the effect that a Performance Bank Guarantee (PBG) of 10% of the order value will be submitted within 15 (fifteen) days of the receipt of Supply Order from IIIT Bangalore.	Based on our various bagging of Govt PO's, we request that the submission of 10% PBG may please be allowed in 30 days as now day's issuing bank requires their Head Office approval before issuance of any PBG.	No Change

04	Section-II, Clause No. 12.7, Page No 11	In case of discrepancy between words and figures, the rates quoted in words shall be treated as final. The amount will be calculated by multiplying correct price with quantity and in case of any discrepancy, the corrected amount shall be considered and total of all corrected amount shall be bidder's total quoted amount.	We request this clause to be read as - In case of discrepancy between rate / unit and total figures, the rates quoted on per unit basis shall be treated as final. The amount will be calculated by multiplying correct price per unit with quantity and in case of any discrepancy in the total amount of bidder's bid, the corrected amount by IIIT Bangalore shall be considered for arriving bidder's total amount quoted	Change is accepted. Revised Price Schedule is provided in Annexure III
05	Section III: Page 14, Clause 7	The successful bidder must submit a Performance Bank Guarantee (PBG) of 10% of the order value within 15 days of receipt of supply order by IIIT Bangalore as per the format provided (Section V3-Performance Bank Guarantee) in the tender document. This Bank Guarantee should remain valid six months beyond the period of delivery, installation & warranty.	The successful bidder must submit a Performance Bank Guarantee (PBG) of 10% of the order value within 30 days of receipt of supply order by IIIT Bangalore as per the format provided (Section V3-Performance Bank Guarantee) in the tender document. This Bank Guarantee should remain valid for Two months beyond the period of delivery, installation & warranty.	No change.
06	Section I, clause 2.1(b), Page 4	Earnest Money in the form of Demand Draft/ Bank Guarantee of Rs. 14.28 Lacs from any Nationalized/Scheduled Bank, in favor of 'International Institute of Information Technology, Bangalore' payable at Bangalore as mentioned at Para 6 (Section II).	Kindly provide IIIT Bank details for processing the Earnest Money Deposit in the form of Bank Guarantee	Refer IIIT response at S. No 1 here above.
07	Section 1, clause 2.1(d), page 4	Self-Attested copy of GST, PAN and Registration certificate, as applicable or relevant company documents as per the Governing laws of the bidder country.	Kindly change - Self-Attested copy of GST, PAN and Registration certificate, as applicable or relevant company documents as per the Governing laws of the bidder country for Tax & company registration	No Change

08	Section 1, clause 2.1(i) page 4	<p>The copy of Supply Orders/ Contracts/ Agreements issued by/ signed with Government of India (Ministry/ Department/ Undertaking/ PSU/ Educational Institutions such as IIT's, NIT's, or other such Central Universities/Banking sector/IT-SEZs/Technology parks/ Stock/Commodity exchanges and reputed private organizations including educational institutions in India) similar work, executed by the bidders in last five years ending March 31st 2018. Foreign bidders can submit Government orders for their country of origin. The bidder should enclose the completion certificate duly issued by the end user. The bidder should have completed at least ONE similar work not less than Rs. 5.71 Crore OR TWO similar works not less than Rs. 3.57 Crore OR THREE similar works not less than Rs. 2.84 Crore. The similar work means supply &amp; installation &amp; on-site support of all/ most of the items mentioned in this tender document in a single project on turnkey basis in India/ abroad.</p>	<p>Based on nature of items desired, we wish to submit that in private orders there is no completion reports available as it is only the supplies and commissioning by vendor. We therefore request you to kindly allow to submit the notarized PO copies for private orders.</p>	No Change
09	Section II, page 7	<p>Eligibility Criteria and &amp; the schedule of requirement</p>	<p>As the items desired / required are manufactured by all kind of small, mid or big time manufacture. There will be no quality or comparison check for such high esteemed based project requirement. You are requested to kindly confirm what kind of level / kind of OEM, bidders should be quoting in order to have fair tender comparison and the supply</p>	<p>In order to maintain the supply, installation &amp; commissioning of products of highest standards &amp; repute from the OEM's the clause 4.8 is added stating that - "Bidder should enclose valid Certificates for their Original Equipment Manufacturer (OEM) i.e. ISO 9001:2015, ISO 14001:2015, ISO 50001:2011, ISO 18001:2007, and BIFMA Level 2</p>

			of low grade products / quality to MIIT is avoided during the procurement process.	
10	Section II, clause 12.7, page 11	In case of discrepancy between words and figures, the rates quoted in words shall be treated as final. The amount will be calculated by multiplying correct price with quantity and in case of any discrepancy, the corrected amount shall be considered, and total of all corrected amount shall be bidder's total quoted amount	Please confirm if amount need to be mentioned in word also in Commercial bid.	Refer IIIT response at S. No 4 here above.
11	Section III, clause 6, page 14	Payments: i. IIIT Bangalore shall release 70% of the payment on delivery of the tendered items at MIIT and certification by MIIT/Indian Mission in Myanmar; ii. Payment of 30% of the purchase order value will be made after the satisfactory successful installation and commissioning of the tendered items on certification by MIIT/ Indian Mission in Myanmar. iii. In case of foreign bidders who quoted in US \$, letter of credit(LC) will be opened and payment would be released as per 7(1) and 7(2).	In terms of Payment We think that you need to relax little.	No Change.
12	Section 1, clause 2.1(j) , page 5	The installation and warranty services are required in Myanmar. The bidder should submit along with the technical bid; the detail plan for providing warranty service at site(s). The bidders should have their own branch office/ service centre in Myanmar or plans to provide service through local dealer/ service provider there. In either case, an undertaking to this effect should be submitted along with the	We have a local set up/Service provider for the after sales service in ASSAM which is very near to Myanmar .IS it OK if we use their service instead of Myanmar Locally.	The setup & erection of supplied items based on local site condition is key to the success of project. Bidder will be required to enclose undertaking from local support provider based in Myanmar along with technical Bid

		<p>technical bid. The details viz. name, address, contact person, telephone / fax, email etc. should be provided along with an undertaking from this local dealer/ service provider within 30 (thirty) days of the receipt of Supply Order from IIIT Bangalore (if applicable).</p>		
13	Section III, Clause 5, Warranty, page 13	<p>All the items covered in the schedule of requirements, shall carry minimum 2 (Two) years on site comprehensive warranty from the date of its installation &amp; commissioning. The bidder must undertake to provide the installation and warranty service in Myanmar. The repairing/ rectification/ replacement/ configuration required, if any, must be done at site only. During the warranty, all complaints should be rectified within 7 days from the time of complaint. In case the rectification of fault involves replacement of some hardware the same should be carried out within 21 days from the date of intimation. Failure to do so would result in the invoking of the PBG. The PBG will be released by IIIT Bangalore only after the submission of satisfactory performance certificate issued by MIIT / Indian Mission &amp; end-user after the completion of warranty period. The Purchaser reserves the right to reject any set of equipment found defective within 30 days after the date of acceptance of equipment. The cost towards replacement will have to be borne by the supplier.</p>	<p>What all are the support will be there in Myanmar. As this will be a different country. Will need the local support there.</p>	<p>Bidder is requested to make it own arrangement at its own risk &amp; cost while quoting for the tendered items which shall cover all aspect of proper packaging, insurance, freight, logistics, custom clearance, door delivery, installation, commissioning, staying during installation &amp; commissioning and extending the warranty services within the price quoted by the bidder at MIIT Myanmar. However MIIT / Indian Mission shall only provide the relevant documents for the custom clearance rest successful bidder's needs to take care. The setup &amp; erection of supplied items based on local site condition is key to the success of project. Bidder will be required to enclose undertaking from local support provider based in Myanmar along with technical Bid</p>
14	Section III, clause 2	<p>Taxes and Duties: 2.1. The prices quoted should be inclusive of all</p>	<p>How this sale will be treated? Is it will be an Export sales or a domestic</p>	<p>The exact nature of query is not clear.</p>

		<p>taxes and /or duties except customs duty. The items being imported in Myanmar from India/Third Country will be exempted from payment of customs duty. Necessary Custom Duty Exemption Certificate shall be provided by Government of Myanmar. The Indian Mission in Myanmar will facilitate in obtaining the custom duty exemption certificate. 2.2. Bidder shall arrange to clear the consignment after following customs formalities at Myanmar and arrange to deliver the consignment to the end user. The cost and risk of the consignment rests with the bidder till it is delivered to the end user. 2.3. The basic prices and applicable taxes should be mentioned separately. The exact rates of taxes applicable, if any, as on the date of quoting must be mentioned. No concessional tax form (C/D) will be given by IIIT Bangalore.</p>	<p>sale with GST .How we will treat this sale as export .Are we going to get the export benefit. Import Export License is required? Please clarify this in details. If I need to Bill IIIT Bangalore in INR or I need to bill to MIIT Myanmar. Is we need to do all the custom formalities in India /Myanmar .What all are the documents IIIT Bangalore will provide. I need to now this point in details.</p>	
15	Section III, clause 5	<p>Warranty. All the items covered in the schedule of requirements, shall carry minimum 2 (Two) years on site comprehensive warranty from the date of its installation &amp; commissioning. The bidder must undertake to provide the installation and warranty service in Myanmar. The repairing/ rectification/ replacement/ configuration required, if any, must be done at site only. During the warranty, all complaints should be within 7 days from the time of complaint. In case the rectification of fault involves replacement of some hardware the same</p>	<p>What type of Warranty you need. These all are Furniture and normal wear &amp; tear will be there as per the usage. Otherwise we will provide a manufacturer defect warranty. Is it OK.</p>	<p>Two years on site comprehensive warranty as per tender through local support provider.</p>



		should be carried out within 21 days from the date of intimation. Failure to do so would result in the invoking of the PBG. The PBG will be released by IIT Bangalore only after the submission of satisfactory performance certificate issued by MIIT / Indian Mission & end-user after the completion of warranty period. The Purchaser reserves the right to reject any set of equipment found defective within 30 days after the date of acceptance of equipment. The cost towards replacement will have to be borne by the supplier.		
16	Section IV, Schedule of Requirement, SI no 12	Speaker Stand / Podium	No description of the Podium that what material is to be used.PI clarify.	The podium should be manufactured of using plyboards
17	Section IV, Schedule of Requirement		In BOQ line items there are 22 items but in image there are 24 items. I think by mistake there is a repetition. PI provide the fresh corrected image for 22 items.	Kindly refer Annexure - 1 here below for better understanding while quoting.
18	Section IV, Schedule of Requirement, SI no 15-19	Student Table with Sitting Bench of 3 Students	Need the clear Image/Drawings for student Table with seating Desk. It is not clear.	The specifications mentioned in drawings are outlined in Technical Specification. Kindly note the Desk dimensions from S. No 15 – 19 of technical specification in tender shall have Minimum 1800 Width or above. Rest Depth & Height remains same for item no 15 – 19 of technical specification. Kindly refer Annexure 1 & Annexure 2 here below.
19	Technical Specifications – SI no 1	Executive table with Side Table	You have asked for particle board is 15 mm, but the availability of board is 18mm, and measurement of site unit is not there. Overall dimension is not clear.	No change. The design remain unchanged. For amended specs refer Annexure 2 here below
20	Technical Specifications – SI no 9	Conference Room Table	Can we supply the leg in particle board other than teak wood leg?	No Change
21	Technical Specifications – SI no 13	Computer Table	You have asked for MDF board is 15mm, but the availability is 18mm	No Change

22	Technical Specifications – SI no 23	Workstation Pedestal	Given picture is CPU Trolley- Shall be supply CPU Trolley?	No Change.
23	Technical Specifications – SI no 23	Podium	Material for Podium is not specified? Particle board/MDF board?	This has been already answered in S.No 16 above
24	Section-1, 2.1(g)  Relevant ISO certificate in Interiors/Furnishing or IT/Lab Infrastructure	Relevant ISO certificate in Interiors/Furnishing or IT/Lab Infrastructure	IIIT has not mentioned the versions of ISO Certificate. So you are requested to please add the version of ISO Certificates. The Main version of ISO Certificates is: ISO 9001:2015, ISO 14001:2015, OSHAS 18001:2007, ISO 50001:2011. Also we would request you to add the following Certificates to get the best quality of furniture and reputed manufacturer which are as follows: BIFMA Membership Certificate Indian Green Building Council (IGBC) Certificate AIOTA Certificate	No change for Bidder. For OEM/Manufacturer refer s. no 9 here above
25	Section 1, clause 2.1(b)	Earnest Money in the form of Demand Draft/ Bank Guarantee of Rs. 14.28 Lacs from any Nationalized/Scheduled Bank, in favour of 'International Institute of Information Technology, Bangalore' payable at Bangalore as mentioned at Para 6 (Section II).	Please allow the earnest money deposit to be submitted in the form of FDR	No Change
26	Section 1, clause 2.1(i)	The copy of Supply Orders/ Contracts/ Agreements issued by/ signed with Government of India (Ministry/ Department/ Undertaking/ PSU/ Institutions such as IIT's, NIT's, or other such Central Universities/Banking sector/IT-SEZs/Technology parks/ Stock/Commodity exchanges and reputed private organizations including educational institutions in India) similar work, executed by the bidders in last five years ending March 31st 2018. Foreign bidders	Please allow that similar work for the valuation purpose should mean – supply installation and on-site of support of interior work / furnishing / furniture's and fixtures / setting up of lab / classroom infrastructure in a single project on turnkey basis in India / abroad.	Change accepted

		<p>can submit Government orders for their country of origin. The bidder should enclose the completion certificate duly issued by the end user. The bidder should have completed at least ONE similar work not less than Rs. 5.71 Crore OR TWO similar works not less than Rs. 3.57 Crore OR THREE similar works not less than Rs. 2.84 Crore. The similar work means supply &amp; installation &amp; on-site support of all/ most of the items mentioned in this tender document in a single project on turnkey basis in India/ abroad.</p>		
27	Section III, clause 7	<p>Performance Bank Guarantee (PBG): The successful bidder must submit a Performance Bank Guarantee (PBG) of 10% of the order value within 15 days of receipt of supply order by IIIT Bangalore as per the format provided (Section V3–Performance Bank Guarantee) in the tender document. This Bank Guarantee should remain valid six months beyond the period of delivery, installation &amp; warranty.</p>	<p>Incase of award for supply order, we request you to allow the submission of 10% PBG in 40 days from the date of supply order.</p>	No change
28	Section III, clause 5	<p>Warranty: All the items covered in the schedule of requirements, shall carry minimum 2 (Two) years on site comprehensive warranty from the date of its installation &amp; commissioning. The bidder must undertake to provide the installation and warranty service in Myanmar. The repairing/ rectification/ replacement/ configuration required, if any, must be done at site only. During the warranty, all complaints should be rectified within 7 days from the time of complaint. In case the rectification of fault</p>	<p>Please allow warranty to be read as 1 year warranty instead of 2 years.</p>	No Change

		involves replacement of some hardware the same should be carried out within 21 days form the date of intimation. Failure to do so would result in the invoking of the PBG. The PBG will be released by IIIT Bangalore only after the submission of satisfactory performance certificate issued by MIIT / Indian Mission & end-user after the completion of warranty period. The Purchaser reserves the right to reject any set of equipment found defective within 30 days after the date of acceptance of equipment. The cost towards replacement will have to be borne by the supplier		
29	Section 1, clause 4	Date of submission of bids and opening of the Technical bids	Please extend the date of bid by submission by 1 week based on corrigendum	No change
30			Please confirm if the items have to be quoted and supplied from the reputed / leading furniture manufacturer. If yes what are the criteria's to be considered while offering the leading OEM products against the requirement laid by your institute.	Yes, Kindly refer IIIT response at S. No 9 here above.
31	Section 1, clause 2.1(b)	Earnest Money in the form of Demand Draft/ Bank Guarantee of Rs. 14.28 Lacs from any Nationalized/Scheduled Bank, in favour of 'International Institute of Information Technology, Bangalore' payable at Bangalore as mentioned at Para 6 (Section II).	Kindly provide the International Institute of Information Technology Bangalore bank details for enabling us to process the Earnest Money Deposit as it is required by our bank to process the earnest money deposit.	Refer IIIT response at S. No 1

32		Only the authorised distributors/ resellers are allowed to bid for the items mentioned in the tender document. The specific authorisation letter from Principal/s clearly indicating that the bidder is competent to sell & provide services for the items mentioned in the Scope of Supply given in this tender document should be enclosed	Being in industry of providing various solutions to our key clients both in private/government, we request you to kindly confirm the original equipment manufacturer parameters apart from the MAF required for desired products to be quoted by various bidders as now a days products are available from low range to high range.	Kindly refer IIIT response at S. No 9 here above.
33	Section II, clause 4.2	The copy of Supply Orders/ Contracts/ Agreements issued by/ signed with Government of India (Ministry/ Department/ Undertaking/ PSU/ Educational Institutions such as IIT's, NIT's, or other such Central Universities/Banking sector/IT-SEZs/Technology parks/ Stock/Commodity exchanges and reputed private organizations including educational institutions in India) similar work, executed by the bidders in last five years ending March 31st 2018. Foreign can submit Government orders for their country of origin. The bidder should enclose the completion certificate duly issued by the end user. The bidder should have completed at least ONE similar work not less than Rs. 5.71 Crore OR TWO similar works not less than Rs. 3.57 Crore OR THREE similar works not less than Rs. 2.84 Crore. The similar work means supply & installation & on-site support of all/ most of the items mentioned in this tender document in a single project on turnkey basis in India/ abroad.	Regarding PO's required as eligibility we request you to kindly change it to be read as Single PO of 5 Cr, Two PO of 3 Cr, Three PO of 2 Cr.	No Change
34	Section III, clause 5	Warranty: All the items covered in the schedule	Regarding warranty requirements please clarify	Refer tender clause.

		<p>of requirements, shall carry minimum 2 (Two) years on site comprehensive warranty from the date of its installation &amp; commissioning. The bidder must undertake to provide the installation and warranty service in Myanmar. The repairing/ rectification/ replacement/ configuration required, if any, must be done at site only. During the warranty, all complaints should be rectified within 7 days from the time of complaint. In case the rectification of fault involves replacement of some hardware the same should be carried out within 21 days from the date of intimation. Failure to do so would result in the invoking of the PBG. The PBG will be released by IIIT Bangalore only after the submission of satisfactory performance certificate issued by MIIT / Indian Mission &amp; end-user after the completion of warranty period. The Purchaser reserves the right to reject any set of equipment found defective within 30 days after the date of acceptance of equipment. The cost towards replacement will have to be borne by the supplier</p>	<p>if the vendor after delivery / installation / will need to repair / replace the furniture incase it is found to be physical damage by the user.</p>	
35	Section III, clause 7	<p>Performance Bank Guarantee (PBG): The successful bidder must submit a Performance Bank Guarantee (PBG) of 10% of the order value within 15 days of receipt of supply order by IIIT Bangalore as per the format provided (Section V3–Performance Bank Guarantee) in the tender document. This Bank Guarantee should remain valid six months beyond the period of delivery,</p>	<p>Please confirm why the validity of Performance Bank Guarantee (PBG) is required beyond warranty period for six months. You are requested to kindly consider the PBG for the period of warranty ie., 2 (two) years only.</p>	No change.

		installation & warranty.		
	10% Performance Bank Guarantee Format	10% Performance Bank Guarantee	As per the Performance Bank Guarantee (PBG) , format it is understood that the PBG has to be made in INR. Please clarify if foreign bidders also have to submit the PBG in INR as per format given or if we can submit on their behalf.	Performance Bank Guarantee shall be required in INR only.
36	Section 1, clause 2.1(m)	Undertaking to the effect that a Performance Bank Guarantee (PBG) of 10% of the order value will be submitted within 15 (fifteen) days of the receipt of Supply Order from IIIT Bangalore.	Recently there has been a lot of changes in various bank policies and in order to submit the Performance bank guarantee in 15 days is too less time frame for any vendor. Therefore request IIIT Bangalore to allow the submission of Performance Bank Guarantee in atleast 30-35 working days from the date of supply order issued by IIIT Bangalore	No Change
37	Section III, Clause 6.1(e)	Payments: i. IIIT Bangalore shall release 70% of the payment on delivery of the tendered items at MIIT and certification by MIIT/Indian Mission in Myanmar; ii. Payment of 30% of the purchase order value will be made after the satisfactory successful installation and commissioning of the tendered items on certification by MIIT/ Indian Mission in Myanmar. iii. In case of foreign bidders who quoted in US \$, letter of credit(LC) will be opened and payment would be released as per 7(1) and 7(2)	IIIT Bangalore is requested to accept/amend the payment terms as following. 6.1. IIIT Bangalore shall release 10% payment in advance against the submission of 10% Performance Bank Guarantee. 6.2. IIIT Bangalore shall release 50% of the payment on dispatch of the tendered items against the submission of shipping documents viz., Invoice, packing list, copy of AWB/BL & Insurance. 6.3. IIIT Bangalore shall release payment of 20% of the purchase order value after successful delivery at MIIT and certification by MIIT/Indian Mission in Myanmar. 6.4.IIIT Bangalore shall release balance payment of 20% after successful installation and commissioning of the tendered items on certification by MIIT/Indian Mission in Myanmar.  Note: Incase of foreign bidder who quoted in US\$, letter of credit (LC) will be	No change

			opened and payment would be made as 6.1, 6.2, 6.3 mentioned here above. Payment as per clause no 6.4 shall be paid by IIIT Bangalore after submission of required documents.	
38	Section I, clause 2.1(d)	Self-Attested copy of GST, PAN and Registration certificate, as applicable or relevant company documents as per the Governing laws of the bidder country.	Kindly correct the same in Bid Submission form as – Self attested copy of GST, PAN, and registration certificate as applicable or relevant company documents as per the governing laws of the bidder country.	No change



## Annexure I

### Schedule of Requirement

S. No	Item Description	Qty	UOM	Specification S. No as per tender document
1	3 Seater Sofa	5	Nos	As per S. No 3
2	Almirah with 4 Shelves	22	Nos	As per S. No 4
3	Centre Table	15	Nos	As per S. No 7
4	Chairs (High Back)	82	Nos	As per S. No 2
5	Chairs with steel legs	80	Nos	As per S. No 22
6	Computer Chairs	243	Nos	As per S. No 14
7	Computer Tables	240	Nos	As per S. No 13
8	Conference Room Table (15' x 4')	6	Nos	As per S. No 9
9	Dias Chair	10	Nos	As per S. No 20
10	Glass Door Almirah with 4 Shelves	14	Nos	As per S. No 12
11	Safe box	2	Nos	As per S. No 6
12	Speaker Stand - Podium	12	Nos	As per S. No 24
13	Student Table with Sitting Bench of 3 Students - (Minimum W 1800 x 895 D x 750 H)	126	Nos	As per S. No 15
14	Student Table with Sitting Bench of 3 Students - (Minimum W 1800 x 895 D x 780 H)	42	Nos	As per S. No 16
15	Student Table with Sitting Bench of 3 Students - (Minimum W 1800 x 895 D x 830 H)	42	Nos	As per S. No 17
16	Student Table with Sitting Bench of 3 Students - (Minimum W 1800 x 895 D x 860 H)	42	Nos	As per S. No 18
17	Student Table with Sitting Bench of 3 Students - (Minimum W 1800 x 895 D x 890 H)	42	Nos	As per S. No 19
18	Table for Labs & Auditorium (5 x 3)	86	Nos	As per S. No 21
19	Table with three drawers	63	Nos	As per S. No 8 & 11
20	Executive Table with Side Table	2	Nos	As per S. No 1
21	Visitor Chairs with Steel legs	170	Nos	As per S. No 5
22	Workstation Pedestal	80	Nos	As per S. No 23
23	Installation & Commissioning of all items at Site.	1	Lump Sum	

**Annexure – 2**  
**Drawings & specifications**

**S. No 1 Executive Table (PIC – 1) with Side Table's**

**PIC - 1**



**Pic 2**



**Pic 3**

- Should be made from high quality particleboard of minimum 15mm and covered with polyurethane laminate.
- Should have Table top thickness of minimum 16 mm and made of pre-laminated particleboard (Melamine finish).
- Wire management should be provided.
- Common lock for drawers and pedestal should be provided.
- Shall have Bush at the bottom which are in contact against the floor.
- Colour – Should have Walnut colour of Executive table.
- Executive side table shall have Right Side 3 drawer cabinet with Dimension (in MM) of 450 (W) x 450 (D) x 675 (H).
- Executive side table shall have Left side Two Door Storage Cabinet with minimum 1 internal shelf & Dimension (in MM) of cabinet should be minimum 900 (W) x 450 (D) x 675 (H) (Refer Pic: 3).
- Dimension (in MM): Should have minimum 2195 (W) X 1455 (D) X 750 (H)

**S. No 15. Student Table with Sitting Bench of 3 Students to be read as - (Minimum W 1800 x 895 D x 750 H)**

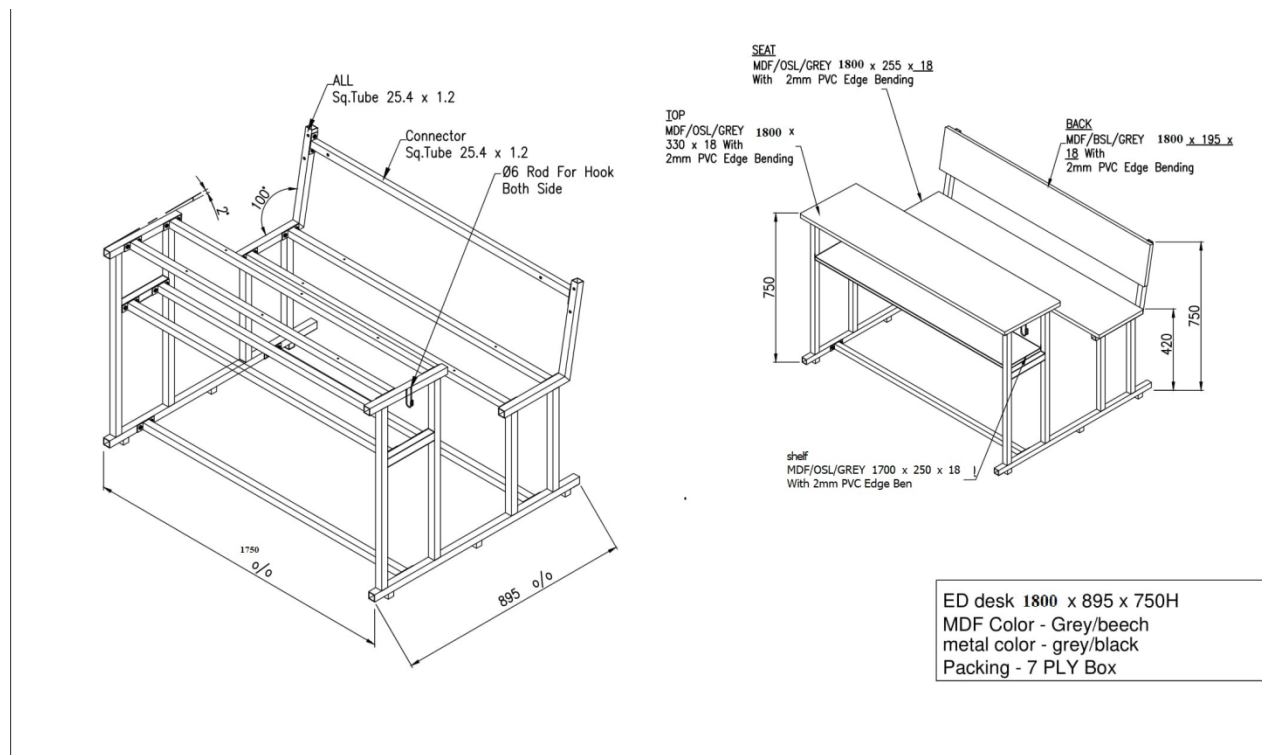

**Read Specs as following for S. No 15. Student Table with Sitting Bench of 3 Students to be read as - (Minimum W 1800 x 895 D x 750 H)**

- Shall have Metal All Sq. Tube 25.4 x 1.2
- Shall have connector Sq. Tube 25.4 x 1.2
- Shall have Rod Hook for Both Side
- Shall have Table Top of MDF/OSL/Grey Minimum 1800 x 330 x 18 with 2mm PVC Edge Bending,
- Shall have Shelf of MDF/OSL/Grey Minimum 1700 x 250 x 18 with 2mm PVC Edge Bending
- Shall have Seat of MDF/OSL/Grey Minimum 1800 x 255 x 18 with 2mm PVC Edge Bending
- Shall have Back Rest of MDF/BSL/Grey Minimum 1800 x 195 x 18 with 2mm PVC Edge Bending
- Shall have MDF Color – Grey / Beech

- Shall have Metal Color – Grey / Black
- Total Desk with sitting shall have Dimension Minimum 1800 W x 895 D x 750 H

**S. No 16. Student Table with Sitting Bench of 3 Students to be read as - (Minimum W 1800 x 895 D x 780 H)**

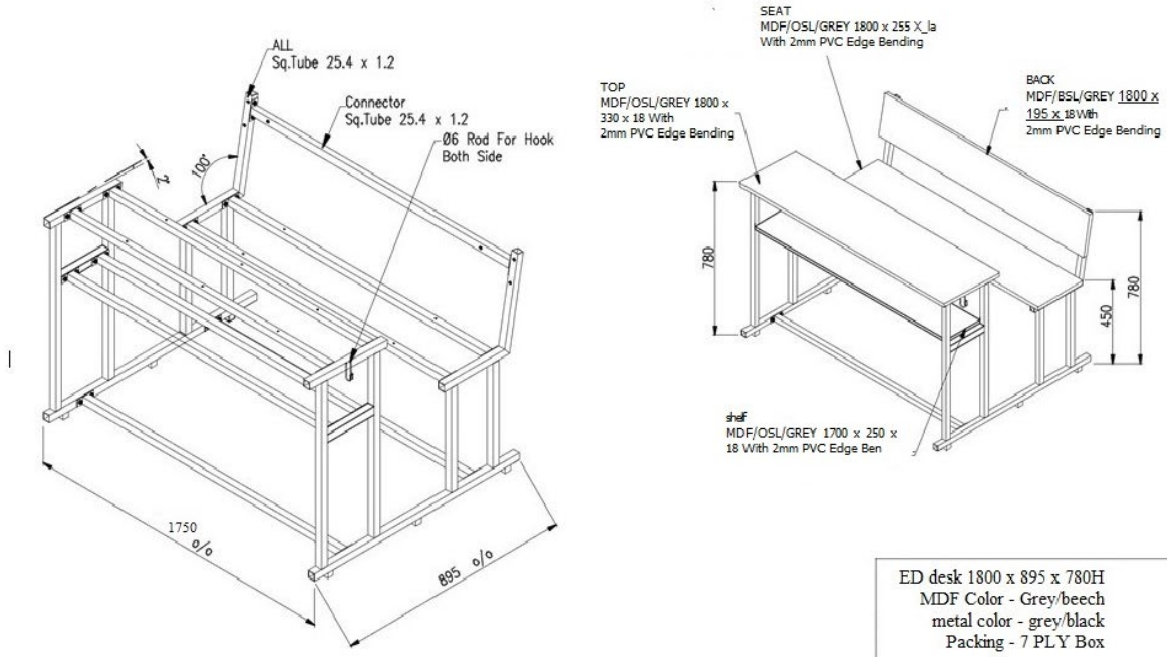

**Read Specs as following S. No 16. Student Table with Sitting Bench of 3 Students to be read as - (Minimum W 1800 x 895 D x 780 H):**

- Shall have Metal All Sq. Tube 25.4 x 1.2
- Shall have connector Sq. Tube 25.4 x 1.2
- Shall have Rod Hook for Both Side
- Shall have Table Top of MDF/OSL/Grey Minimum 1800 x 330 x 18 with 2mm PVC Edge Bending,
- Shall have Shelf of MDF/OSL/Grey Minimum 1700 x 250 x 18 with 2mm PVC Edge Bending
- Shall have Seat of MDF/OSL/Grey Minimum 1800 x 255 x 18 with 2mm PVC Edge Bending
- Shall have Back Rest of MDF/BSL/Grey Minimum 1800 x 195 x 18 with 2mm PVC Edge Bending
- Shall have MDF Color – Grey / Beech
- Shall have Metal Color – Grey / Black

- Total Desk with sitting shall have Dimension Minimum 1800 W x 895 D x 780 H

**S. No 17. Student Table with Sitting Bench of 3 Students to be read as - (Minimum W 1800 x 895 D x 830 H)**

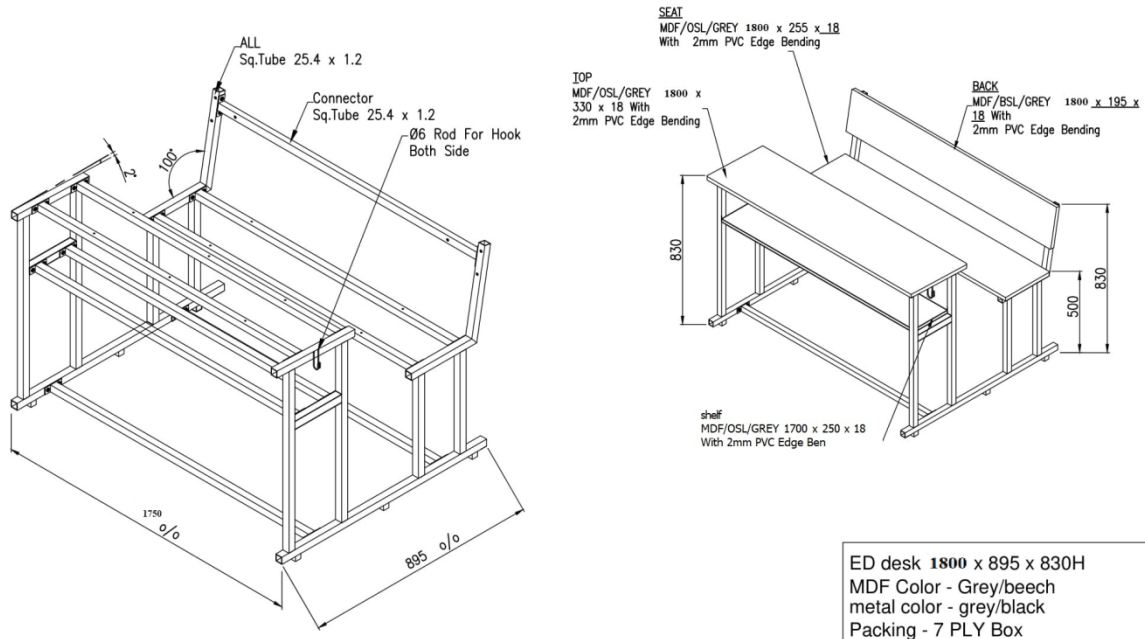

**Read Specs as following for S. No 17. Student Table with Sitting Bench of 3 Students to be read as - (Minimum W 1800 x 895 D x 830 H):**

- Shall have Metal All Sq. Tube 25.4 x 1.2
- Shall have connector Sq. Tube 25.4 x 1.2
- Shall have Rod Hook for Both Side

- Shall have Table Top of MDF/OSL/Grey Minimum 1800 x 330 x 18 with 2mm PVC Edge Bending,
- Shall have Shelf of MDF/OSL/Grey Minimum 1700 x 250 x 18 with 2mm PVC Edge Bending
- Shall have Seat of MDF/OSL/Grey Minimum 1800 x 255 x 18 with 2mm PVC Edge Bending
- Shall have Back Rest of MDF/BSL/Grey Minimum 1800 x 195 x 18 with 2mm PVC Edge Bending
- Shall have MDF Color – Grey / Beech
- Shall have Metal Color – Grey / Black
- Total Desk with sitting shall have Dimension Minimum 1800 W x 895 D x 830 H

**S. No 18. Student Table with Sitting Bench of 3 Students to be read as - (Minimum W 1800 x 895 D x 860 H)**

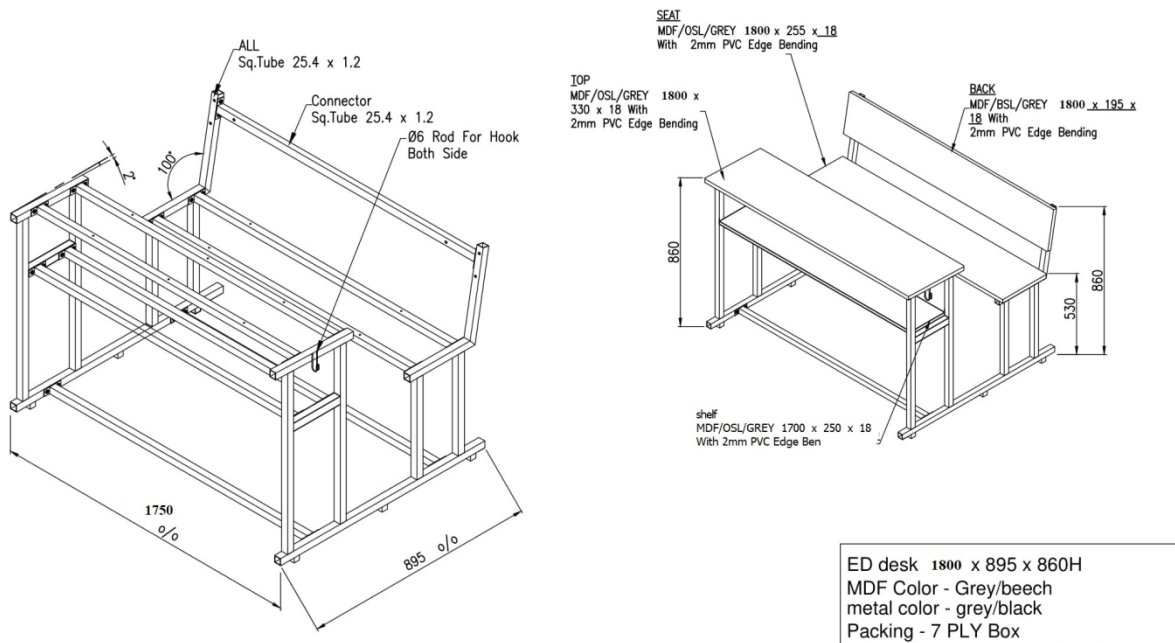

**Read Specs as following S. No 18. Student Table with Sitting Bench of 3 Students to be read as - (Minimum W 1800 x 895 D x 860 H):**

- Shall have Metal All Sq. Tube 25.4 x 1.2
- Shall have connector Sq. Tube 25.4 x 1.2
- Shall have Rod Hook for Both Side
- Shall have Table Top of MDF/OSL/Grey Minimum 1800 x 330 x 18 with 2mm PVC Edge Bending,
- Shall have Shelf of MDF/OSL/Grey Minimum 1700 x 250 x 18 with 2mm PVC Edge Bending
- Shall have Seat of MDF/OSL/Grey Minimum 1800 x 255 x 18 with 2mm PVC Edge Bending
- Shall have Back Rest of MDF/BSL/Grey Minimum 1800 x 195 x 18 with 2mm PVC Edge Bending
- Shall have MDF Color – Grey / Beech
- Shall have Metal Color – Grey / Black
- Total Desk with sitting shall have Dimension Minimum 1800 W x 895 D x 860 H

**S. No 19. Student Table with Sitting Bench of 3 Students to be read as - (Minimum W 1800 x 895 D x 890 H)**

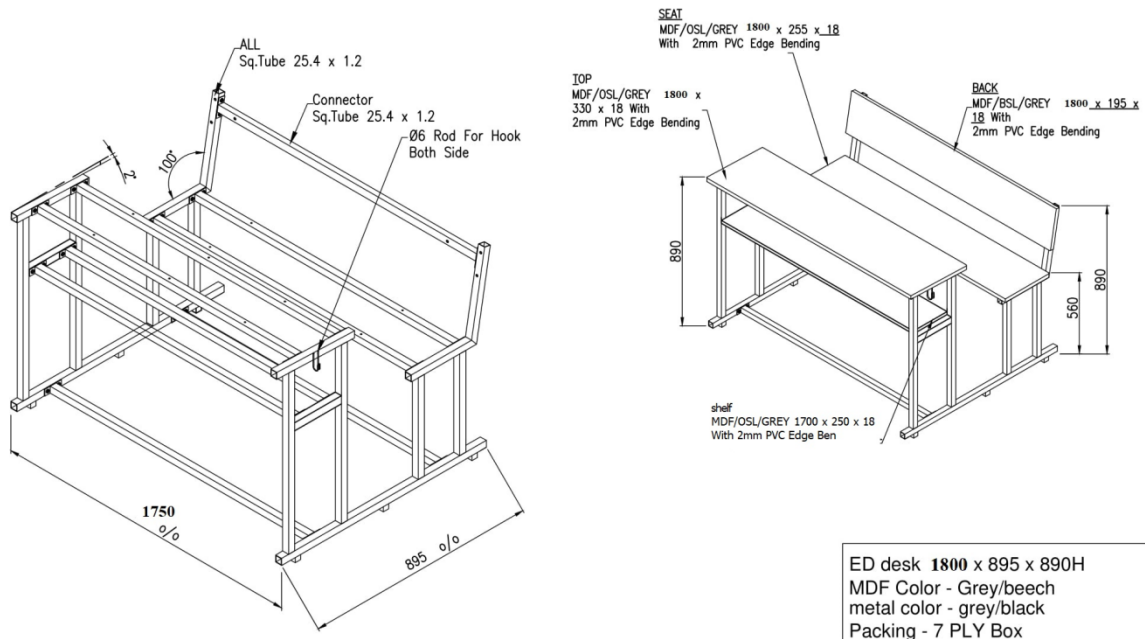

**Read Specs as following S. No 19. Student Table with Sitting Bench of 3 Students to be read as - (Minimum W 1800 x 895 D x 890 H):**

- Shall have Metal All Sq. Tube 25.4 x 1.2
- Shall have connector Sq. Tube 25.4 x 1.2
- Shall have Rod Hook for Both Side
- Shall have Table Top of MDF/OSL/Grey Minimum 1800 x 330 x 18 with 2mm PVC Edge Bending,
- Shall have Shelf of MDF/OSL/Grey Minimum 1700 x 250 x 18 with 2mm PVC Edge Bending
- Shall have Seat of MDF/OSL/Grey Minimum 1800 x 255 x 18 with 2mm PVC Edge Bending
- Shall have Back Rest of MDF/BSL/Grey Minimum 1800 x 195 x 18 with 2mm PVC Edge Bending
- Shall have MDF Color – Grey / Beech
- Shall have Metal Color – Grey / Black
- Total Desk with sitting shall have Dimension Minimum 1800 W x 895 D x 890 H



## Annexure – III

### SECTION V – COMMERCIAL

#### PRICE SCHEDULE

SL.No	Item Description	Total Qty	UOM	Rate/Unit (INR/USD )	Taxes (INR/USD )	Rate/Unit (INR/USD )	Grand Total (INR/USD )
		(X)		A	B	A + B = C	C x (X)
1	3 Seater Sofa	5	Nos				
2	Almirah with 4 Shelves	22	Nos				
3	Centre Table	15	Nos				
4	Chairs (High Back)	82	Nos				
5	Chairs with steel legs	80	Nos				
6	Computer Chairs	243	Nos				
7	Computer Tables	240	Nos				
8	Conference Room Table (15' x 4')	6	Nos				
9	Dias Chair	10	Nos				
10	Glass Door Almirah with 4 Shelves	14	Nos				
11	Safe box	2	Nos				
12	Speaker Stand/Podium	12	Nos				
13	Student Table with Sitting Bench of 3 Students (W 1200 x 895 D x 750 H)	126	Nos				
14	Student Table with Sitting Bench of 3 Students - (W 1200	42	Nos				

	x 895 D x 780 H)						
15	Student Table with Sitting Bench of 3 Students - (W 1200 x 895 D x 830 H)	42	Nos				
16	Student Table with Sitting Bench of 3 Students - (W 1200 x 895 D x 860 H)	42	Nos				
17	Student Table with Sitting Bench of 3 Students - (W 1200 x 895 D x 890 H)	42	Nos				
18	Table for Labs & Auditorium (5 x 3)	86	Nos				
19	Table with three drawers	63	Nos				
20	Executive Table with Side Table	2	Nos				
21	Visitor Chairs with Steel legs	170	Nos				
22	Workstation Pedestal	80	Nos				
23	Installation & Commissioning of all items at Site.	1	Lum p Sum				
<b>Sub Total (INR / USD)</b>							
<b>Discount (If any)</b>							
<b>Grand Total (INR / USD)</b>							
<b>Grand Total in Words</b>							

**Note**

1. Do not quote optional items against the requirement mentioned in this tender.
2. Discount (if any) to be offered should be mentioned against in the respective cell provided above. In case it is mentioned elsewhere it will not be considered for the purpose of price comparison.
3. If there is a discrepancy between the unit price and total price THE UNIT PRICE shall prevail.
4. **The bidder must quote for all the items mentioned under Section IV – Schedule of Requirement. The lowest price criteria shall be applied on the total composite amount of all items taken together.**
5. **If the bidder quotes for partial items mentioned under Section IV – Schedule of Requirement, the bid might be liable to be rejected.**